

INSTALLATION DOCUMENTATION	9/11/2004	KIT MOTO	Suzuki GSX R 2003-2004 600 – 750 – 1000cc
Installation procedure for the Suzuki GSX-R- 2003-2004 kit – Vers. 1.00			

MXL Pista / MXL Strada PLUG & PLAY KIT FOR SUZUKI GSX R 2003-2004



KIT DESCRIPTION

The **MXL Plug & Play** kit for **Suzuki GSX-R** is composed of the following objects:

- **MXL Pista** or **MXL Strada**
- Plug and play wiring for **MXL Pista** or **MXL Strada**
- Installation kit including: 1 bracket, 2 M5 + 2 thread forming screws, 4 anti-vibration mountings, washers
- Gyroscope (optional) needed to map tracks
- CD-ROM including **Race Studio 2** software
- Documentation

MXL^(*) kit for **Suzuki GSX-R** has been developed for the following cubic capacities: 600 cc, 750 cc, 1000 cc. Please, refer to the following table to understand which **Suzuki GSX-R** is supported by our kit.

Cubic capacity (cc)	Year 2003	Year 2004
600	√	√
750	√	√
1000	√	√

√ = supported

• = NOT supported

(*) When you find **MXL** this means we are speaking of **MXL Pista** and **MXL Strada**

The **MXL Pista / MXL Strada - Suzuki GSX-R** version has been designed and developed in order to be a “plug and play” system you can connect to the “on-board” wiring. The aim of this kit is to merge the functionalities of the stock dash together with the ones of a professional data acquisition system.

MXL Pista / MXL Strada - Suzuki GSX-R version may be used both on track (lap times, split times, engine’s parameters, gyroscope to map tracks) and on street (odometer, water temperature, oil pressure alarm, fuel level).

The gauge, as the stock dash, is powered by the bike’s master switch. Moreover, when installing your **MXL Pista / MXL Strada**, you do not have to cut, to bend or to drill anything: each component of the kit has been designed to be plug and play.

The gauge has to be connected to the standard head light using the bracket supplied with the system. The bracket is made in black anodized aluminum, in order to be lightweight and mechanically resistant.

GENERAL NOTES – Read this before installing the system

- Do not cut any wiring: the wiring supplied with the kit is plug and play.
- Please, be careful not to damage the on-board connectors when plugging/unplugging them. In the following pages is described how to correctly manage them.
- Do not install the system when the engine is hot. The on-board connectors are quite near to the engine and you can burn yourself.
- The space under the gas tank is quite confined: be careful not to hurt yourself when plugging and unplugging the connectors. If necessary, please remove the gas tank in order to have a wider available space.
- Be careful not to loose screws and washers.
- Do not damage the fairing when installing/uninstalling it.

INSTALLATION STEP # 1 – Removing lateral mirrors, frontal and lateral fairing.

The first installation step consists in removing the two external mirrors, the frontal and the lateral fairings.

The mirrors are fixed to the bike chassis with two hexagonal screws covered by a plastic cover. First of all, please remove the black plastic cover as in **Figure 1**



Figure 1: black plastic covers removal.

Then, please, remove the hexagonal screws you see in **Figure 2**. Please remember that both external lateral mirrors have to be removed.



Figure 2: hexagonal screw.

Once the external mirrors have been removed, you can remove the front transparent fairing and the right lateral fairing.

It is suggested to remove the front fairing in order to uninstall the stock dash and install the new one in an easier way.

The front transparent fairing is locked to the chassis using 4 Phillips recess screws. In **Figure 3** is shown the location of the four screws: please remove them.

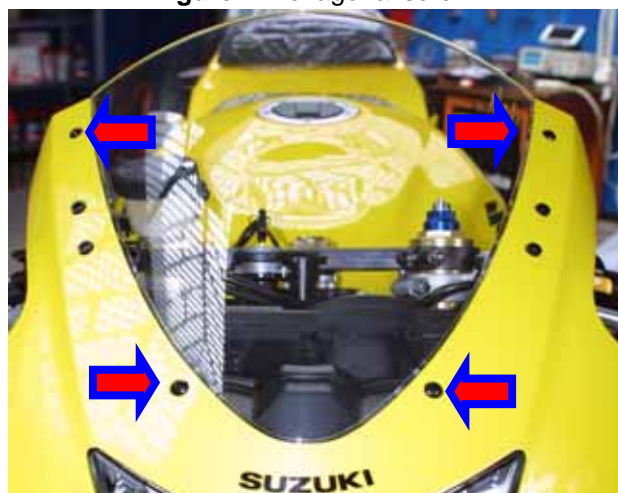

Figure 3: Front fairing – 4 Phillips recess screws.

The gauge's wiring has to be installed on the right side of the bike. For this reason, removing bike's right lateral fairing is necessary (left lateral fairing is not needed to be removed).

The lateral fairing is fixed to the chassis with 6 hex screws and 4 plastic pins.

The screws are red circled in **Figure 4**, while the pins are highlighted with a red/yellow arrow in **Figure 4** and **Figure 5**. In particular, the plastic pin shown in **Figure 4** is located close to the front splash-guard and to the front fork; this pin is visible only if front looking the bike.

Note: blue / red arrow is explained later (see **Figure 13**).



Figure 4: Right lateral fairing – screws/pins location

The other 3 plastic pins are located in the lower part of the bike.
In order to correctly remove them, please see **Figures 6 and 7**.

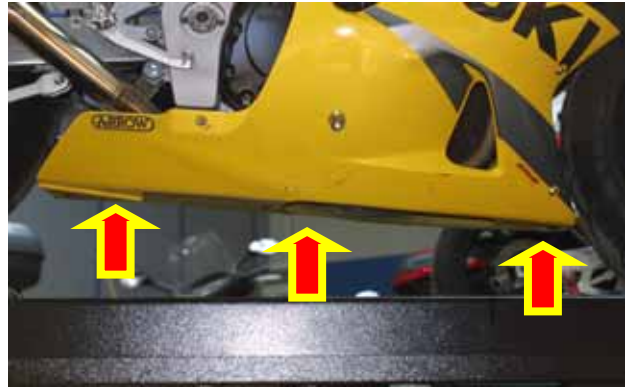

Figure 5: Junction between right and left fairing – pins location.

Please, insert a tip in the central hole of the pin and press until you hear a click. This way you unlock the pin.



Figure 6: Unlocking the central clip of the plastic pin.

Once unlocked the pin, please remove it using a flat screwdriver: insert it under the pin and rotate it.
Remember to repeat this proceeding for the three pins.
Once all hex screws and pins have been removed, you may uninstall the right lateral fairing.



Figure 7: removing the plastic pin

INSTALLATION STEP # 2 – Removing the seat and uplifting the bike's gas tank.

As some of the bike's connectors are very close to the engine and are located under the gas tank, it is necessary to uplift the gas tank.

To uplift the gas tank, is first of all necessary to remove the driver's seat, that is fixed to the bike's chassis with two screws. In **Figure 8** you can see, highlighted with a red/yellow arrow, the position of the left screw.



Figure 8: Seat

Please unscrew the 2 hex screws located on the right and left side of the bike as shown in **Figure 9**.

Once unscrewed them, you may remove the driver's seat.



Figure 9: Unscrewing seats screw

The gas tank is hinged to the chassis near to the driver's seat and is fixed with 2 hex screws near to the front fork. Please unscrew them as shown in **Figure 10**.



Figure 10: How to remove the gas tank

Once removed the 2 hex screws, you may uplift the gas tank using the bracket supplied with the bike's standard equipment as shown in **Figure 11**.



Figure 11: Uplifting the gas tank

INSTALLATION STEP # 3 – Slackening the headlight and the fairing screws.

The third installation step consists in slackening fairing and headlight screws, in order to easily install your kit. These screws are Phillips Recess one. In **Figure 12** is highlighted the position of one of the two remaining fairing screws. Please note, in that figure the screw has already been unscrewed.



Figure 12: position of fairing and headlight screws

After having slackened these screws, you can pull (carefully) toward you the front fairing, as shown in **Figure 13**, to be able to fix the lateral screws of your new dash (see **Figures 28 and 30** for further information).

When you pull the fairing toward you, be careful not to detach the headlight: it can fall down.

Please note: to be able to pull toward you the fairing you should have already removed all frontal and lateral screws and frontal pins. For further information concerning the position of the pins, please see Figure 4. The screws you have to remove are also these symmetric to these highlighted with a blue/yellow arrow in Figure 4



Figure 13: the fairing and the headlight screws have been slackened.

INSTALLATION STEP # 4 – Removing the stock dash and unplugging the on board connectors

The fourth installation step consists in removing the stock dash and unplugging the “on-board” connectors.

The stock dash is fixed to the bike in 4 points: in 2 of them is screwed with two 5 mm hex screws, while in the other 2 points is fixed with a bracket.

First of all, please remove the 5 mm hex screws in the lower part of the stock dash, as highlighted in **Figure 14**.

Once the screw has been removed, you may uninstall the stock dash: please rotate it toward you and pull it away from the head light.



Figure 14: Position of the stock dash front screws.



Figure 15: unplugging the stock dash.

Once removed the stock dash, you have to unplug the AMP 16 pins connector from the dash backside.

As shown in **Figure 16**, please remove the protective plastic cover and, then, push down the locking tongue (highlighted with a red/yellow arrow) and pull out the connector from the dashboard.



Figure 16: unplugging the on board dash connector

Figure 17 shows the standard location of the Gear and Water temperature on-board connectors.

For further information concerning the “on-board” connectors, please see **Figures from 17 to 19**.

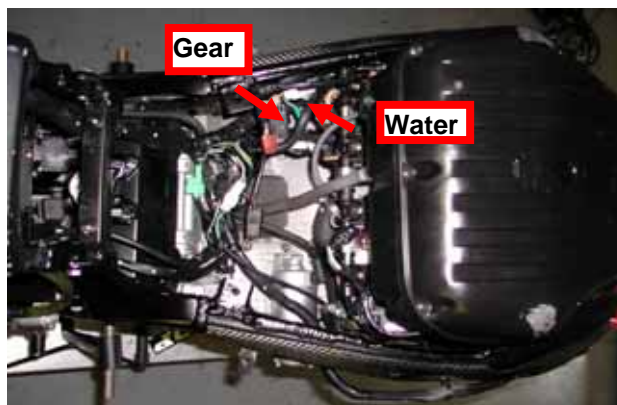

Figure 17: on board connectors – Water temp. / Gear

The on-board **Gear** connector, shown in **Figure 18** is a 3 pins / white coloured connector which is usually located on the bike's left side (as shown in **Figure 17**).

Here below is a drawing of both male and female GEAR connectors.

NOTE: cable colours correspond to the real ones.

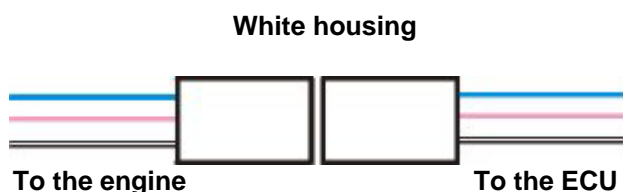

Figure 18: Gear connector – particular

The on-board **Water temperature** connector, shown in **Figure 19**, is a 2 pins / green coloured connector located on the bike's left side (as shown in **Figure 17**).

Here below is a drawing of the water temperature connector.

NOTE: cable colours correspond to the real ones.

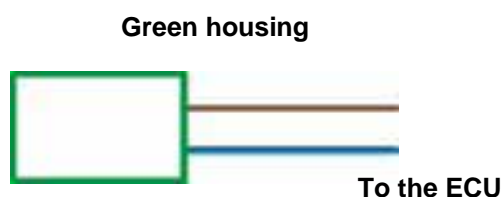

Figure 19: Water temperature connector – particular

NOTE: how to unplug the 3 pins connectors

The 3 pins male/female connectors are firmly plugged together.

In order to unplug the male connector from the female, please use a flat corkscrew to push down the locking tongue and then unplug the 2 connectors.

NOTE: please, be careful to pull the 2 connectors by the housing and not by the wiring (you might seriously damage the wiring unplugging each cable from the 3 pins connector).



Figure 20: How to unplug a connector

INSTALLATION STEP # 5 – Assembling the kit.

The fifth installation step consists in assembling the kit for **Suzuki GSX-R**.

1. The kit you receive, has already mounted the four anti-vibration mountings on the backside of your **MXL**;
2. Install your **MXL** on the aluminium bracket: The bracket has to be fixed to your **MXL** in correspondence of the 4 anti-vibration mounting and has to be fixed using 4 screws and 4 Grover washers.



Figure 21: anti-vibration mountings – particular

Figure 22 shows the correct assembly of **MXL**, bracket and washers (rear view)



Figure 22: MXL and bracket – rear view

INSTALLATION STEP # 6 – Wirings connection.

The sixth installation step consists in installing the wiring supplied with the kit.

The wiring is all contained in a rubber girdle. Please bend down the wiring and then let all the harnesses pass along the right side of the bike.

In order to correctly install the wiring, please follow these instructions:



Figure 23: Wiring installation

1. Let all the wirings (except for channel labelled as “Lap”) pass between the head light and the front fairing chassis as shown in **Figure 24**.
2. Please note that 2 AMP connectors, wiring labelled as “Lap” and “on-board input” wiring (i.e. the one terminated with a black aluminium box), have to remain up to the front fairing chassis. In particular, both AMP connector and channels interface box are too big to pass between chassis and head light: for this reason, we suggest to insert the wiring from the top.



Figure 24: Kit installation

3. Let “Gear”, “Water temp” etc... wirings run along the chassis, as shown in **Figure 25**. Please, use plastic wrappers to fix them to the bike’s stock wiring.
4. “Gear” and “Water temp” on-board connectors are located under the gas tank: for this reason, let these wirings enter the engine compartment, as highlighted in **Figure 25**.
5. As you noticed, “Gear” and “Ch.1 Water temp” cables have 2 connectors: a male and a female. Please, plug the **AIM** wiring’s male connector to the stock wiring’s female connector and the **AIM** wiring’s female connector to the stock wiring’s male connector.



Figure 25: Wiring installation – run the wiring along the chassis

6. Connect the 16 pins black connector to the male connector located inside the black aluminium box (push the connector till you hear a click). See **Figure 26** for further information.
7. Once the 16 pins connector has been plugged, use the plastic cover of the stock dash to make the connection waterproof.



Figure 26: Wiring installation – particular of the AMP connector

INSTALLATION STEP # 7 – Installing the kit.

The seventh installation step consists in plugging the 2 AMP connectors cable to your **MXL**.

Once the connector has been correctly installed, please place the black aluminium box between the bracket and the headlight.

When the channels interface box has been correctly installed (use Velcro or plastic wrappers to fix it), you may mount the assembled kit on the head light.

The new dash has to be fixed in four points. Two of them are front visible (red circled in **Figures 27** and **28**), while the other two are lateral, (highlighted with a red / yellow arrow and yellow circled in **Figures 27** and **28**).

To fix the new dash in the front points, please use the M5 screw you find in the kit, while to fix the new dash in the lateral points, please use the M4 Phillips thread forming screws.



Figure 27: position of the 4 screws.

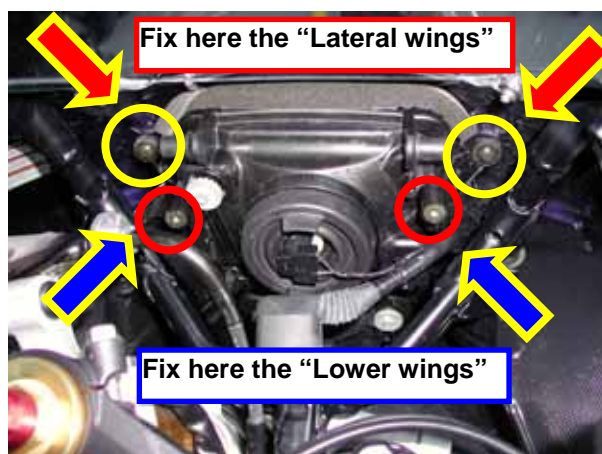

Figure 28: Lateral and lower “wings” fixing positions

To fix the new dash in the lateral points, please use the thread forming screws given with the kit (See **Figure 29** for further information). The screws have to be inserted in the hole high lightened in **Figure 29**.

Please note, the front and the lateral fairing should have already be pulled toward you as said before (See note to **Figure 13).**

Moreover, you may use plastic wrappers to fix the new wirings to the chassis.



Figure 29: fixing the lateral screws

Before re-mounting the lateral fairing, the front fairing, the seat and the gas tank, we suggest you to turn on the bike in order to check the system’s integrity and its correct installation.

FIRMWARE FOR MXL GSX-R - 2003-2004

As your **MXL Suzuki** has been designed both for street and track use and as the information the driver wants to display are different for street and track use, your **MXL Suzuki** is equipped with a special firmware version which provides you with a **second virtual dashboard**.

When you are driving on a street, the display is set to “**street mode**” and shows the following parameters:

- RPM graphical bar: settable upper limit;
- RPM digital value / Battery voltage / Total odometer / Partial odometer / Current date and time: Fuchsia colour (button **VIEW/QUIT** to switch between them);
- Speed: red colour;
- Gear number: green colour;
- 2 fixed analog inputs (not switchable): Blue colour
- 4 switchable analog inputs or static string: Light Blue colour.



Figure 30: Street display

Once you start running on a track and your gauge triggers a lap (you pass in front of a switched-on lap transmitter), the display automatically switches to “**track mode**” and shows the following parameters:

- RPM graphical bar: settable upper limit;
- Lap time / RPM digital value / Battery voltage / Current date and time: fuchsia colour (button **VIEW/QUIT** to switch between them);
- Speed: red colour;
- Gear number: green colour;
- 2 fixed analog inputs (not switchable): Blue colour
- 4 switchable analog inputs or static string: Light Blue colour.



Figure 31: Track display

In order to step back from “**track mode**” to “**street mode**”, please switch off the gauge and then re-switch it on. The gauge sets automatically to “**street mode**”.

NOTE: for further information concerning the display management and its configuration, please refer to the MXL Strada / Pista / PRO user’s manual.

MXL Pista / MXL Strada SUZUKI CONFIGURATION [RACE STUDIO 2]

your **MXL Pista / MXL Strada Suzuki** may be interfaced with the PC in order to:

- download the data stored in the internal memory;
- upgrade the gauge firmware;
- configure the gauge.

Once you buy a **MXL Pista / MXL Strada Suzuki**, the gauge already includes a configuration properly developed for your **Suzuki** bike: all sensors, calibration curves, engine parameters, speed parameters, etc... have already been set to a default value which guarantees you the possibility to plug in the input cable and start running.

Anyway, if you wish to change, for instance, the RPM upper value or the shift lights, if you wish to add a potentiometer sensor or a gyroscope on your **MXL Pista / MXL Strada Suzuki** and you need to calibrate them, if you change the crown or the pinion with a “different teeth number” one, you need to use our software **Race Studio 2**.

The CD-ROM including software, USB drivers, installation documentation and user manual is included in the **MXL Pista / MXL Strada Suzuki** kit. If you have any doubt about software or USB drivers installation, please refer to the installation manual included in the CD-ROM.

The following table shows the input channels for **MXL Pista / MXL Strada Suzuki**.

MXL Pista - Suzuki

Ch. 1	Water temperature
Ch. 2	Free input channel – use RS 2 ^(*)
Ch. 3	Free input channel – use RS 2 ^(*)
Ch. 4	Free input channel – use RS 2 ^(*)
Ch. 5	Free input channel – use RS 2 ^(*)
Ch. 6	Free input channel – use RS 2 ^(*)
Ch. 7	Free input channel – use RS 2 ^(*)
Ch. 8	“On board” gear sensor

MXL Strada - Suzuki

Ch. 1	Water temperature
Ch. 2	Free input channel – Use RS 2 ^(*)
Ch. 3	Oil Pressure
Ch. 4	Free input channel – Use RS 2 ^(*)
Ch. 5	Fuel Level
Ch. 6	Direction Lights
Ch. 7	High Beam
Ch. 8	“On board” gear sensor

(*) RS2 = **Race Studio 2** software

To correctly configure your gauge and use **Race Studio 2**, please follow these instructions.

Run **Race Studio 2** and select “**MXL**” pushbutton in the buttons toolbar. Press “System manager” button and then “New” button: the screenshot shown in **Figure 32** is prompted.

Please, set all configuration parameters (Logger type, vehicle name, speed, temperature and pressure unit of measure, etc...) and then press OK button.



Figure 32: Race Studio 2 – New configuration

Once pressed OK button, System Manager window is prompted on your monitor, as shown in **Figure 33**.

In order to correctly configure the input channels, please select it among the available ones (in **Figure 33**, for instance, there are 2 available configurations: the yellow-highlighted is the selected one) and press button “Channels”.



Figure 33: Race Studio 2 – System manager window

The screenshot in **Figure 34** is prompted.

MXL Strada Suzuki:

This logger has 2 free input channels , Channels labelled an CH. 2 and CH. 4. Clicking in the correspondent cell (row “CH. 2” or row “CH. 4” column sensor type) you may set the input channels among a long list of pre-defined sensors or you may set a custom sensor selecting “custom sensor manager”.

MXL Pista Suzuki:

This logger has 6 free input channels, labelled from CH. 2 to CH. 7. Clicking in the correspondent cell (row “CH 2 / CH. 7” column “Sensor type”) you may set the input channels among a long list of pre-defined sensors or you may set a custom sensor selecting “custom sensor manager”. Moreover, you may set channel name and sampling frequency.

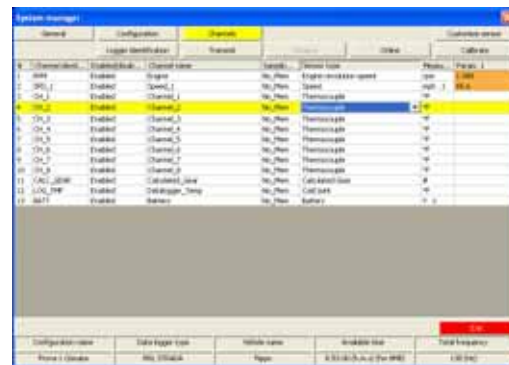

Figure 34: Race Studio 2 – Input channels window

Once all sensors have been correctly set, please press button “Configuration”.

Configuration window (**Figure 35**) allows the user to set shift lights and alarms threshold value, change unit of measure, to modify the speed parameters, etc...

1) Speed:

The speed sensor on your Suzuki bike is installed on the jackshaft which connects the gearbox to the pinion.

The number of magnets installed on this jackshaft is **4**.

The wheel circumference written in the proper cell is an “equivalent circumference” calculated using the following formula:



Figure 35: Race Studio 2 – Configuration window

$$Equiv\ Circumf = \frac{Wheel\ Circumf * N_p}{N_c}$$

N_p = Pinion teeth number - N_c = Crown teeth number

Using the default values for crown/pinion teeth number and wheel circumference for a **Suzuki GSX-R 750**, the equivalent circumference is **801.4 mm (31.55 inches)**.

2) Shift lights:

The values described in the 5 cells may be modified by the user in order to switch on the led at the desired RPM value. The 5 default values are the proper ones for a Suzuki GSX-R 750: in case you have a GSX-R 600 or a GSX-R 1000 you may need to modify such thresholds.

3) RPM:

Please, DO NOT modify the “Multiply factor” (the default value is /1).

To change RPM scale upper limit, please select the desired value among the 7 default ones.

4) Alarm led #1:

As previously described, channel 1 is used for water temperature.

The alarm for channel 1 is defined as a “Maximum alarm”, i.e. the led is switched on when water temperature is higher than the threshold value.

The default value is **90 °C (194 °F)**.

5) Alarm led #2:

- **MXL Strada Suzuki:** alarm led 2 is defined as “Minimum alarm”, i.e. the led is switched on when oil pressure is lower than the threshold value. Default value is **2 Bar (29 PSI)**.
- **MXL Pista Suzuki:** alarm for channel 2 is defined as “Minimum alarm”, i.e. the led is switched on when water temperature is lower than the threshold value. Default value is **50 °C (122 °F)**.

6) Alarm led #3:

- **MXL Strada Suzuki:** alarm led 3 is defined as “Minimum alarm”, i.e. the led is switched on when battery voltage is lower than the threshold value. Default value is **13 V**.
- **MXL Pista Suzuki:** you may set the proper threshold value for the sensor you have installed on channel 3,

7) Alarm led #4:

- **MXL Strada Suzuki:** alarm led 4 is used for fuel level and is defined as “Minimum alarm”. Please do NOT modify threshold value, otherwise you might run out of petrol. Default value is **100** (corresponding to 4 litre – 1 gallon).
- **MXL Pista Suzuki:** you may set the proper threshold value corresponding to the sensor you have installed on channel 4.

8) Alarm led #5:

- **MXL Strada Suzuki:** alarm led 5 is used for turn signal and is defined as “Minimum alarm”. Please do NOT modify threshold value, otherwise you might not see the turn signal on the display. Default value is **250**
- **MXL Pista Suzuki:** you may set the proper threshold value corresponding to the sensor you have installed on channel 5.

9) Alarm led #6:

- **MXL Strada Suzuki** alarm led 6 is used for high beam and is defined as “Maximum Alarm”. Please do NOT modify threshold value. Default value is **250**
- **MXL Pista Suzuki**, you may set the proper threshold values corresponding to the sensor you have installed on channel 6.

10) Gear sensor:

Suzuki plug & play kit allows the user to sample the gear directly from an “on-board” sensor installed inside the gearbox. In order to allow your **MXL** to sample the gear, please do NOT modify the gear sensor default value which is set to **potentiometer**.

Once you set the desired input channels on your **MXL Strada / MXL Pista Suzuki** and/or you set the desired threshold values for the alarm led of the shift lights, **you have to transmit the configuration to the logger: to do so, please press OK button and then “Transmit” button on the next screenshot.**

ATTENTION: before transmitting the configuration, the logger must be connected to the PC as shown in **Figure 36** and the USB drivers must be correctly installed. For further information concerning the USB drivers installation, please refer to the proper manual.

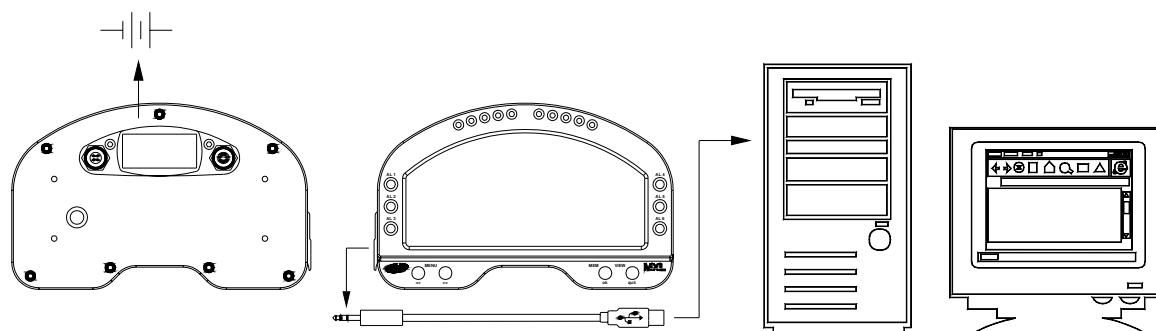

Figure 36: How to connect the logger to the PC

MXL PISTA Suzuki owners:

If you have installed a gyroscope (to map tracks) and/or a fork travel potentiometer (or a rear shock travel potentiometer), these sensors have to be calibrated to sample correct data. Please, click on the “Calibrate” button: the screenshot shown in **Figure 37** appears.

The sensors are divided in 2 categories: the “to be autocalibrated” sensors and the “to be calibrated” ones.

The “to be autocalibrated sensors” are:

- Gyroscope
- Potentiometer distance

The “to be calibrated sensors” are:

- Zero based potentiometer
- Mid zero potentiometer

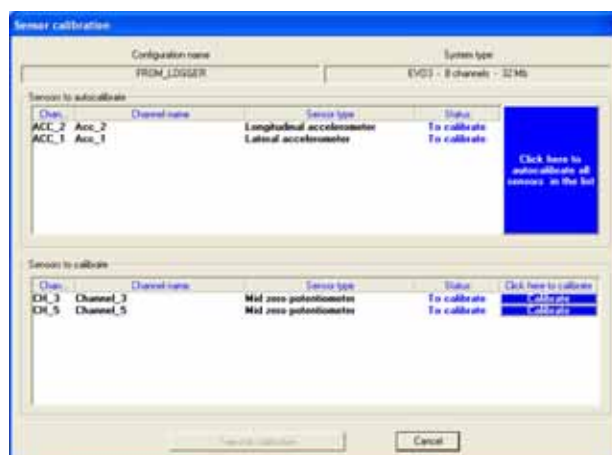

Figure 37: Race Studio 2 – Calibration window

Please, refer to the user manual for further information about calibration / auto-calibration procedure.

Once finished calibrating / auto-calibrating the sensors, you have to transmit the configuration to the logger pressing button “Transmit calibration” inside the “Sensor calibration” window. Now your logger is ready for street and track use.